

CM 76B

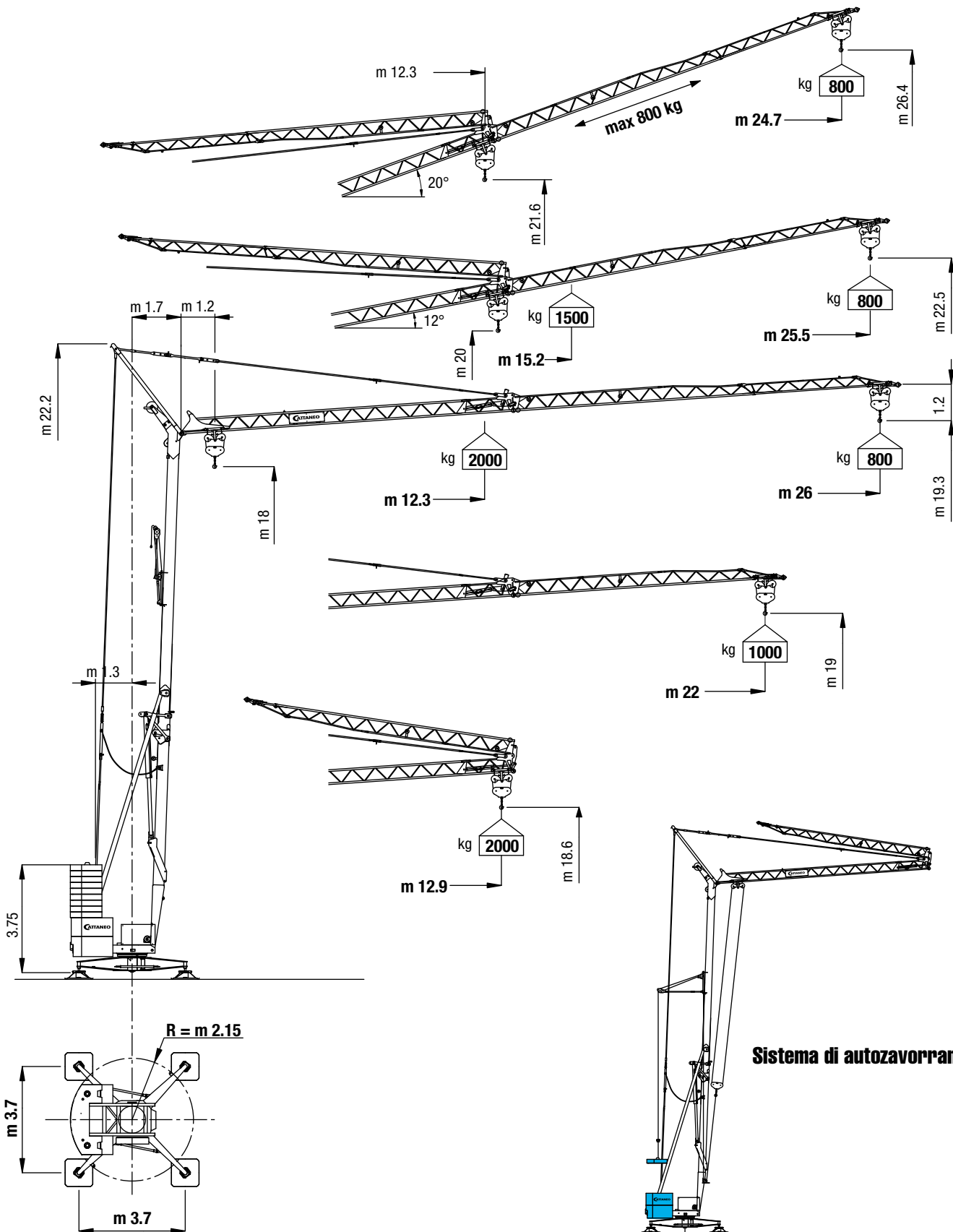





Sistema di autozavorramento

Curve di carico	kg	2000	1800	1600	1500	1400	1200	1000	800
Load diagrams	m	12.3	13.4	14.7	15.5	16.4	18.6	21.6	26.0
Courbes de charge	m	12.4	13.5	14.9	15.7	16.6	18.9	22.0	
Lastkurven	m				15.2	16.1	18.3	21.2	25.5
Curvas de cargas	m								



CM 76B

			1°	2°	3°	4°	CV	kW
 Sollevamento Hoisting Levage Hubwerk Elevación	 m/1'	5	21	32	45	10	7.5	
		kg	2200	2200	1000			1000
 Carrello - Trolley Chariot - Katzfahrwerk Carro	m/1'	24 - 48				4	3	
 Rotazione - Siewing Orientation - Drehwerk Rotación	m/1'	0 → 0.4 → 0.9				3	2.2	
 Potenza elettrica necessaria Necessary electric power Puissance électrique nécessaire Anschlusswert Potencia eléctrica necesaria		10 kW - 400 V - 50Hz						

Contrappeso in lastre di cemento armato - Ferro-concrete ballast slabs
 Contrepoids en plaques de béton armé - Gegenballast aus Stahlbetonplatten - Lastre en hormigón armado

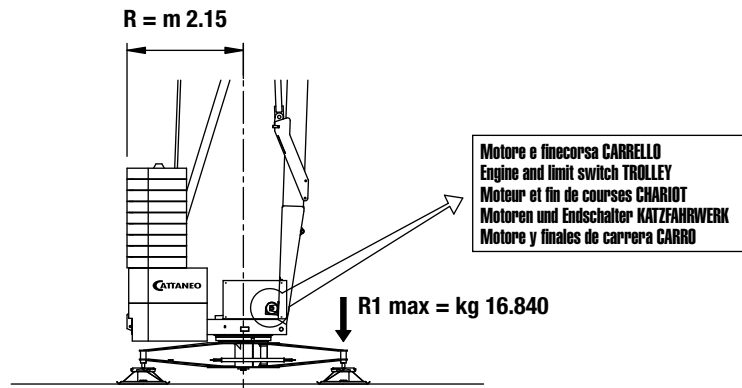

kg 1350 x n. 2 + kg 1450 x n. 2 + kg 850 x n. 9

Massa gru (con assale da cantiere) Weight of crane (with yard axle) Poids de la grue (avec essieu de chantier) Konstruktionsgewicht des Krans (mit Rangierfahrwerk) Peso grúa (con eje para obra)	kg 9.850
Massa contrappeso Counterweight Contrepoids Gegengewicht Contrapeso	kg 13.250

Trasporto - Transport - Transport - Transport - Transporte

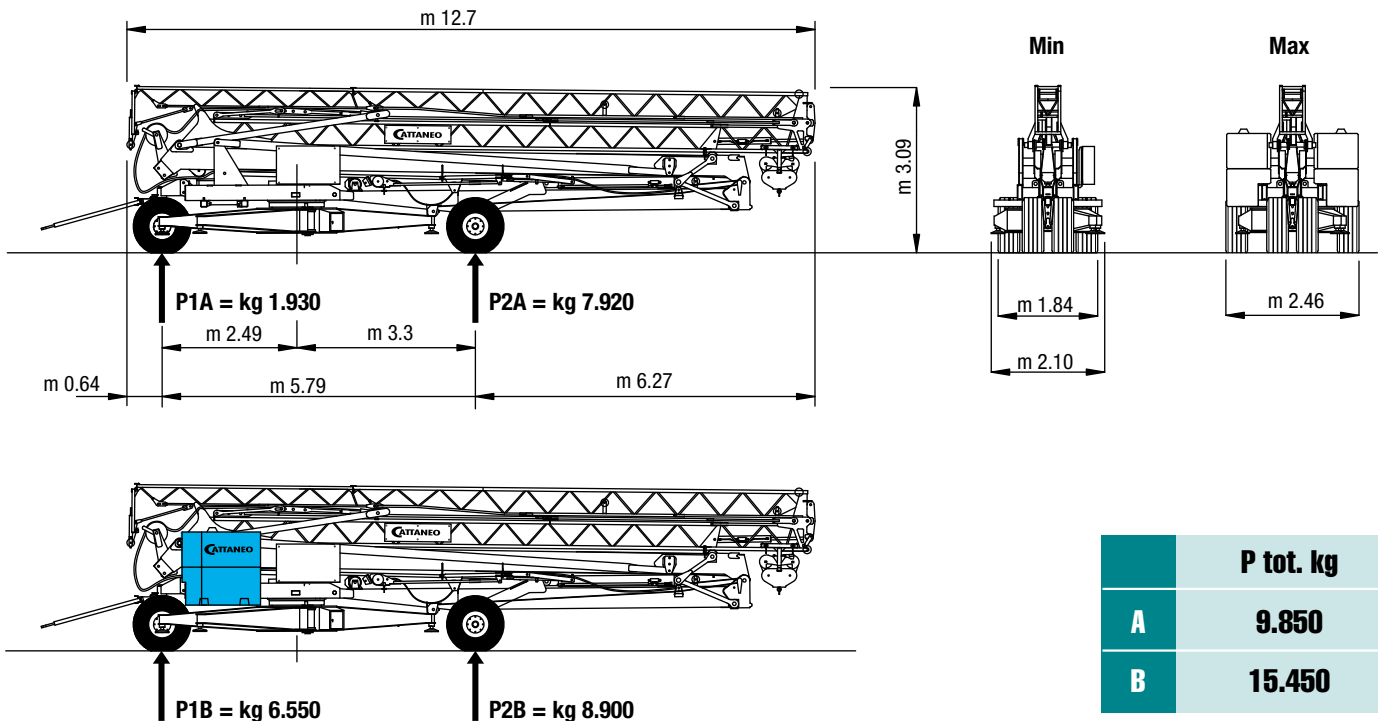

	P tot. kg
A	9.850
B	15.450

CM 76B

MONTAGGIO

- Meccanismo di montaggio oleodinamico automatizzato, con cilindri indipendenti per torre e braccio, comandabili a distanza tramite pulsantiera o radiocomando; allineamento aereo del braccio brevettato, con cilindro indipendente in posizione protetta e stelo rientrato in condizione di esercizio - Pretensionamento delle funi di traslazione a terra e mantenimento della tensione costante per tutto il montaggio - Apertura e chiusura automatica del puntone del braccio durante il montaggio e lo smontaggio - Valvole di blocco su tutti i movimenti dei cilindri e valvola limitatrice di pressione - Microinterruttore di livello olio in centralina - Tubi idraulici senza giunzioni intermedie, con protezioni su tutto il percorso.
- La facoltà di abbassare la gru con il braccio allineato consente una facile e rapida verifica ed un eventuale intervento sul carrello, sui capofissi delle funi e sulle pulegge, senza dover smontare completamente la gru.
- L'accesso, il posizionamento e l'uscita dal cantiere sono agevolati dalla facoltà di montare e smontare la gru su 360°, con ingombri ridottissimi; le operazioni di autolivellamento e di installazione degli assali sono rese rapide e facili con la semplice azione del cilindro di montaggio. Gli spostamenti sono facilitati dal carro gommato a quattro ruote di grande diametro, dalla possibilità di asportare tutto il contrappeso di montaggio e di restringere la carreggiata dell'assale fisso.

Brevettata

Assembling

Positioning and leveling on 360° - Easier moving with great wheels in diameter - Assembling in few minutes in narrow places - Automated oleodynamic assembling with aerial opening of the jib - Remote-controlled independent movements of assembling - Safety valves on the whole system - Microswitch oil level in the gearbox - Minimum encumbrance - Low rotation radius

Patented

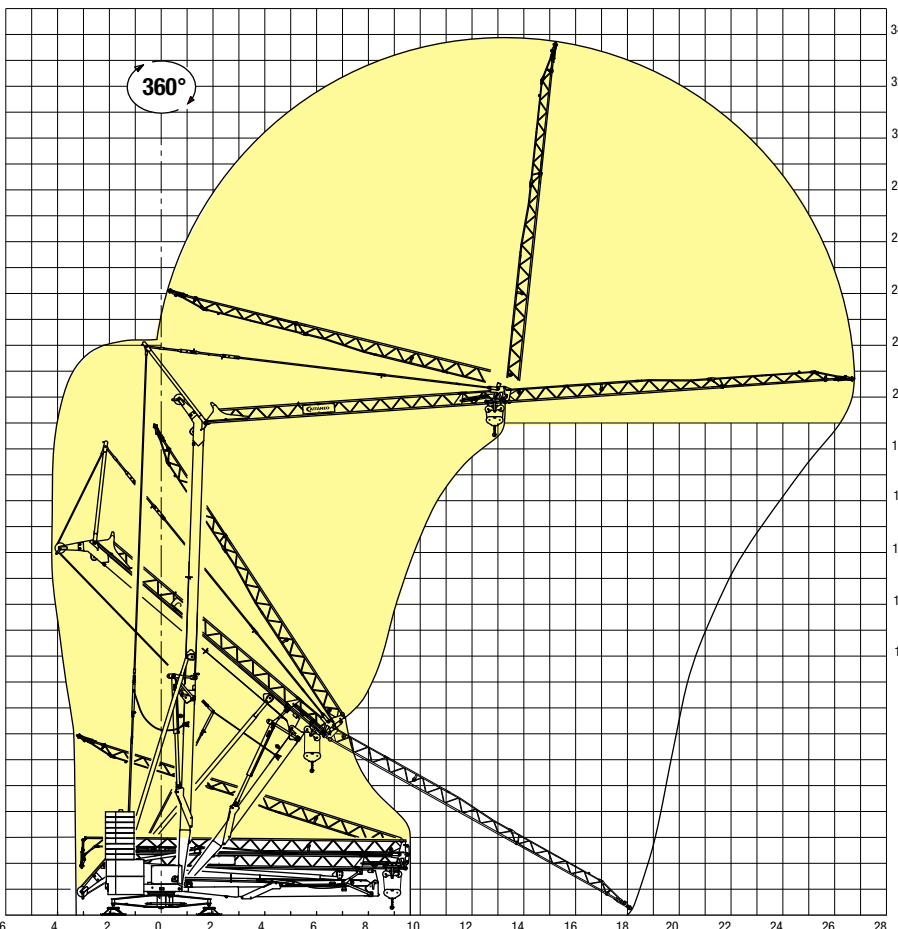

Simple to use High performances Rugged construction Planned for important works

- No electrical component on the jib and on the high parts of the crane. Low mechanism and limit switch of trolley translation with automatic feedback of the translation ropes during the assembling.
- Engines, limit switches, load limiting devices, whole electric system, gauge and oleodynamic gearbox are placed on the base of the crane for an easy maintenance and adjustment on ground.
- Hoisting winch, oleodynamic gearbox and slewing devices protected under integral case; slewing ring with internal protected toothing.
- Transport on lorry within the loading gauge

Mechanisms and equipment

- Galvanization of the tower and the jib
- Folding jib with working crane
- Luffing jib with climbing trolley
- Modular jib
- Hoisting with 3 temporized speeds
- Crab traversing with 2 speeds, with gradual starting
- Electronic control of rotation with "inverter" and countermanoeuvre control
- Cutting out of the electronic hoisting control in case of trouble
- Overload warning horn
- Complete equipment of limit switches and limiters
- Temporized load limiters for the extinction of oscillations
- Double controlled contactors for the "up" and "far" motion
- Protected engines with magnetothermic switches
- "Telemecanique" contactors
- Galvanized ropes
- Stainless steel cabinet of electrical equipment
- Cabinet for equipment and pushbutton board
- Yard axle with 4 wheels
- Assembling and finishing ballast
- Immersion painting with undercoat

Optional equipments

- Distribution plates for bearing on ground
- Selfballasting derrick
- Radio control with pushbutton board or manipulator