

MDT 302 L12

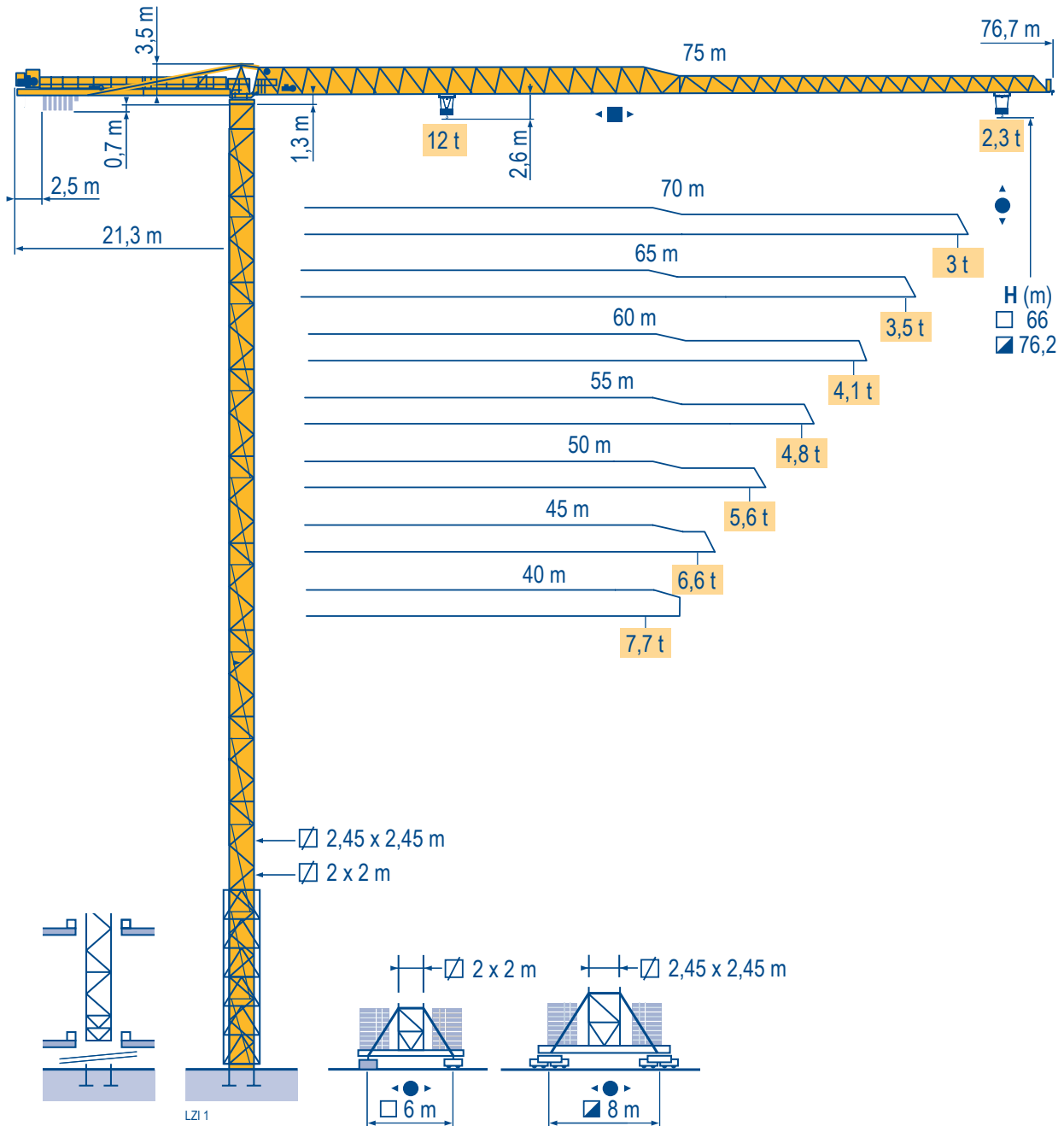

Mat / Réactions \square 2 m
 Maste / Eckdrücke \triangle 40 m \Rightarrow 75 m
 Masts / Reactions
 Mástil / Reacciones
 Torre / Reazioni
 Tramo / Reações

L21 2

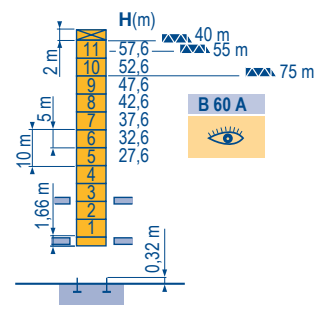
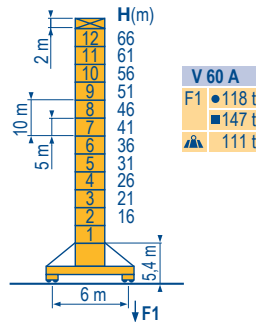
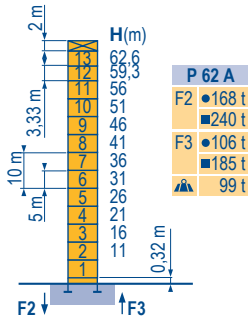

\square 2,45 m
 \triangle 40 m \Rightarrow 75 m

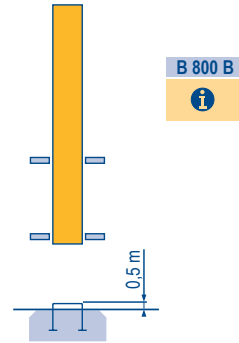
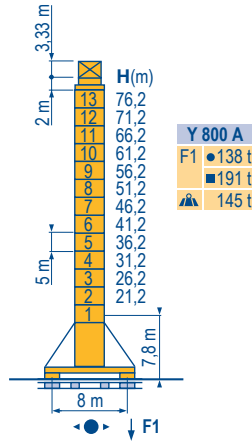
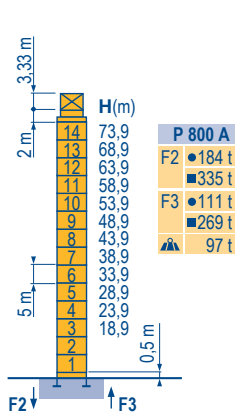

Télescopage sur dalles
 Kletterkrane im Gebäude
 Climbing crane
 Telescopage gruas trepadoras
 Gru in cavedio
 Telescopagem sobre lagas

L21 1

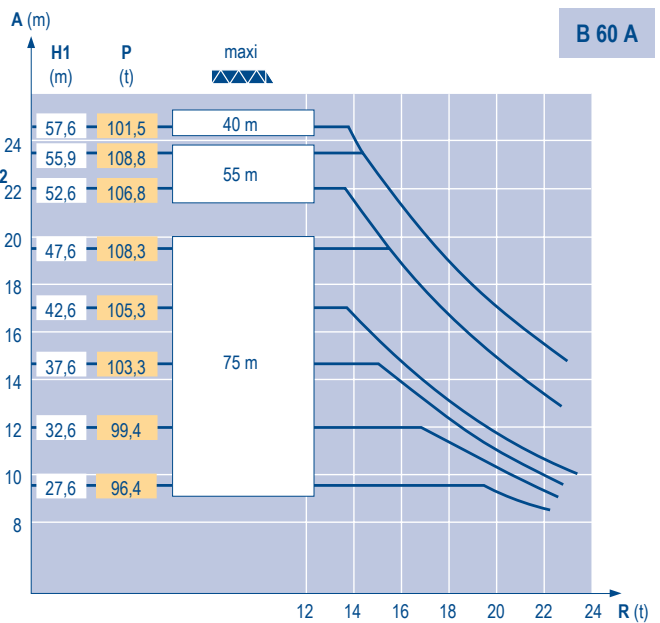
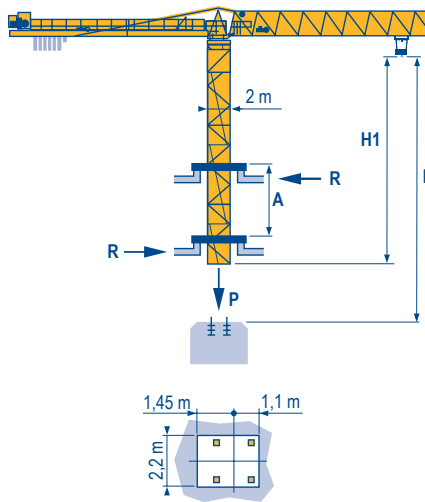

Topless
 MDT 302 L12

POTAIN

F	D	GB	E	I	P
● Réactions en service	● Reaktionskräfte in Betrieb	● Reactions in service	● Reacciones en servicio	● Reazioni in servizio	● Reações em serviço
■ Réactions hors service	■ Reaktionskräfte außer Betrieb	■ Reactions out of service	■ Reacciones fuera de servicio	■ Reazioni fuori servizio	■ Reações fora de serviço
A vide sans lest (ni train de transport) avec flèche et hauteur maximum.	Ohne Last, Ballast (und Transportachse), mit Maximalausleger und Maximalhöhe.	Without load, ballast (or transport axes), with maximum jib and maximum height.	Sin carga, sin lastre, (ni tren de transporte), flecha y altura máxima.	A vuoto, senza zavorra (ne assali di trasporto) con braccio massimo e altezza massima.	Sem carga (nem trem de transporte)- sem lastro com lança e altura máximas.
Nous consulter	Auf Anfrage	Consult us	Consultarnos	Consultateci	Consultar-nos

Courbes de charges

Lastkurven

Load diagrams

Curvas de cargas

Curve di carico

Curva de cargas

L21.1

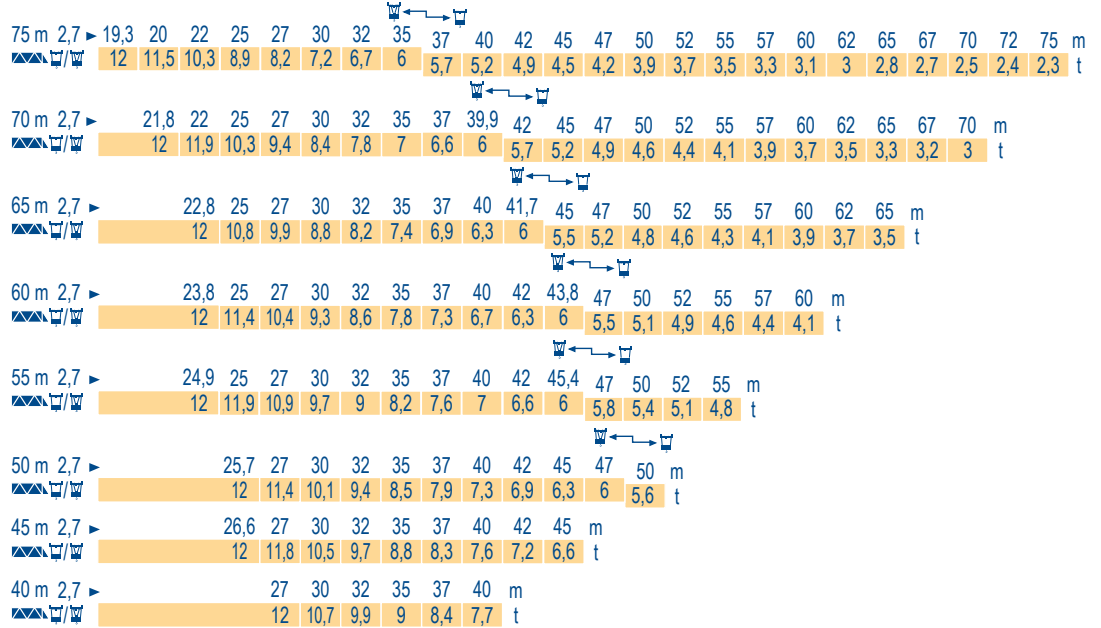

Lest de contre-flèche

Gegenauslegerballast

Counter-jib ballast

Lastre de contra flecha

Contrappeso

Lastros da contra lança

L21.1

Height (m)	3 150 kg - 2 100 kg	
	50 LVF 30	75 LVF 30
75 m	21,3 m	22 050
70 m	21,3 m	19 950
65 m	21,3 m	21 000
60 m	21,3 m	18 900
55 m	21,3 m	18 900
50 m	21,3 m	16 800
45 m	21,3 m	14 700
40 m	21,3 m	12 600

Lest de base

Grundballast

Base ballast

Lastre de base

Zavorra di base

Lastros da base

L21.1

Height (m)	Weights (t)												
	2 m	66	61	56	51	46	41	36	31	26	21	16	
2,45 m	76,2	71,2	66,2	61,2	56,2	51,2	46,2	41,2	36,2	31,2	26,2	21,2	

Topless

MDT 302 L12



	F	D	GB	E	I	P
A	Distance entre cadres	Abstand zwischen den Rahmen	Distance between collars	Distancia entra marcos	Distanza fra i telai	Distância entre quadros
H1	Hauteur grue	Kranhöhe	Crane height	Altura grúa	Altezza gru	Altura da grua
P	Poids de la grue(en service)	Krangewicht (in Betrieb)	Crane weight (in service)	Peso de la grúa (en servicio)	Peso della gru (in servizio)	Peso da grua (em serviço)
R	Réaction horizontale	Horizontalkräfte	Horizontal reaction	Reaccion horizontal	Reazione orizzontale	Reacção horizontal
	Voir télescopage sur dalles	Siehe Kletterkrane im Gebäude	See climbing crane	Veja grua trepadora	Consultare gru in cavedio	Ver telescopagem sobre lages

Mécanismes
Antriebe
Mechanisms
Mecanismos
Meccanismi
Mecanismos

LZI 2

														ch - PS hp	kW												
	50 LVF 30 Optima	m/min	2,4	→	10	→	30	→	38	→	56	→	80	1,2	→	5	→	15	→	19	→	28	→	40	50	37	454 m
	t	6	6	6	4,5	3	1,5	12	12	12	9	6	3														
	75 LVF 30 Optima	m/min	3,8	→	15	→	44	→	58	→	82	→	118	1,9	→	7,5	→	22	→	29	→	41	→	59	75	55	612 m
	t	6	6	6	4,5	3	1,5	12	12	12	9	6	3														
	6 DVF 4	m/min	0 → 50 (12 t) - 0 → 100 (6 t) - 0 → 120 (3 t)												5,5	4											
	RVF 163 Optima +	tr/min U/min rpm	0 → 0,7												3 x 7,5	3 x 5,5											
	V 60 A RT 544 A1 2V R ≥ 13 m	m/min	13,5 - 27												4 x 7	4 x 5,2											
	Y 800 A	m/min																									
CEI 38						IEC 38						kVA															
400V (+6%-10%) 50 Hz												50 LVF : 80 kVA 75 LVF : 105 kVA															

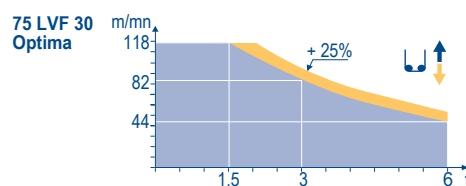
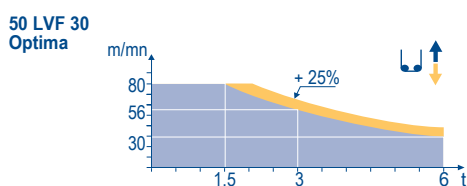

	F	D	GB	E	I	P
	Levage	Heben	Hoisting	Elevación	Sollevamento	Elevação
	Distribution	Katzfahren	Trolleying	Distribución	Distribuzione	Distribuição
	Orientation	Schwenken	Slewing	Orientación	Rotazione	Rotação
	Translation	Kranfahren	Travelling	Traslación	Traslazione	Translação

Document commercial non contractuel. Pour toute information technique se référer à la notice correspondante. Unverbindliches Vertriebsdokument. Für technische Informationen, siehe die entsprechenden Anweisungen. This commercial document is not legally binding. For any technical information, please refer to the corresponding instructions. Documento comercial non contractuel. Para cualquier información técnica, ver la noticia correspondiente. Documento commerciale non vincolante, per tutte le informazioni tecniche fare riferimento al catalogo istruzioni. Documento comercial não contractual. Para qualquer informação técnica complementar consultar as respectivas instruções.

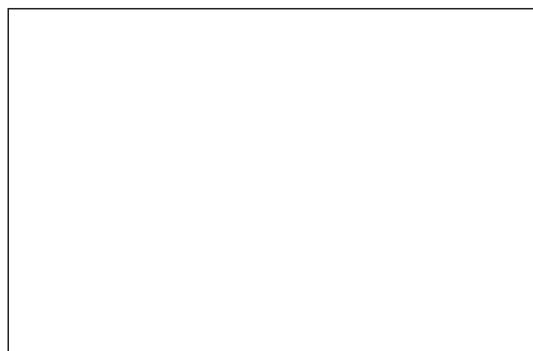

Americas
Tel : +1 888 479 7278
Tel : +1 717 593 2000

Europe - Middle East - Africa
Tel : +33 (0) 4 72 81 50 00
Tel : +44 (0) 191 522 2000

Asia - Pacific
Tel : +65 6264 1188
Fax : +65 6862 4040

www.manitowoccrane.com

18, rue de Charbonnières - B.R.173
69132 ECULLY Cedex - France

Tél. : +33 (0) 4 72 18 20 20
Fax. : +33 (0) 4 72 18 20 00
www.manitowoccrane.com

Topless MDT 302 LZI
Code T-91985-68_Réf. 2003 48 LZI 3

Copyright.Reproduction interdite © POTAIN 2003

Réalisation Secotec