

OMV 300

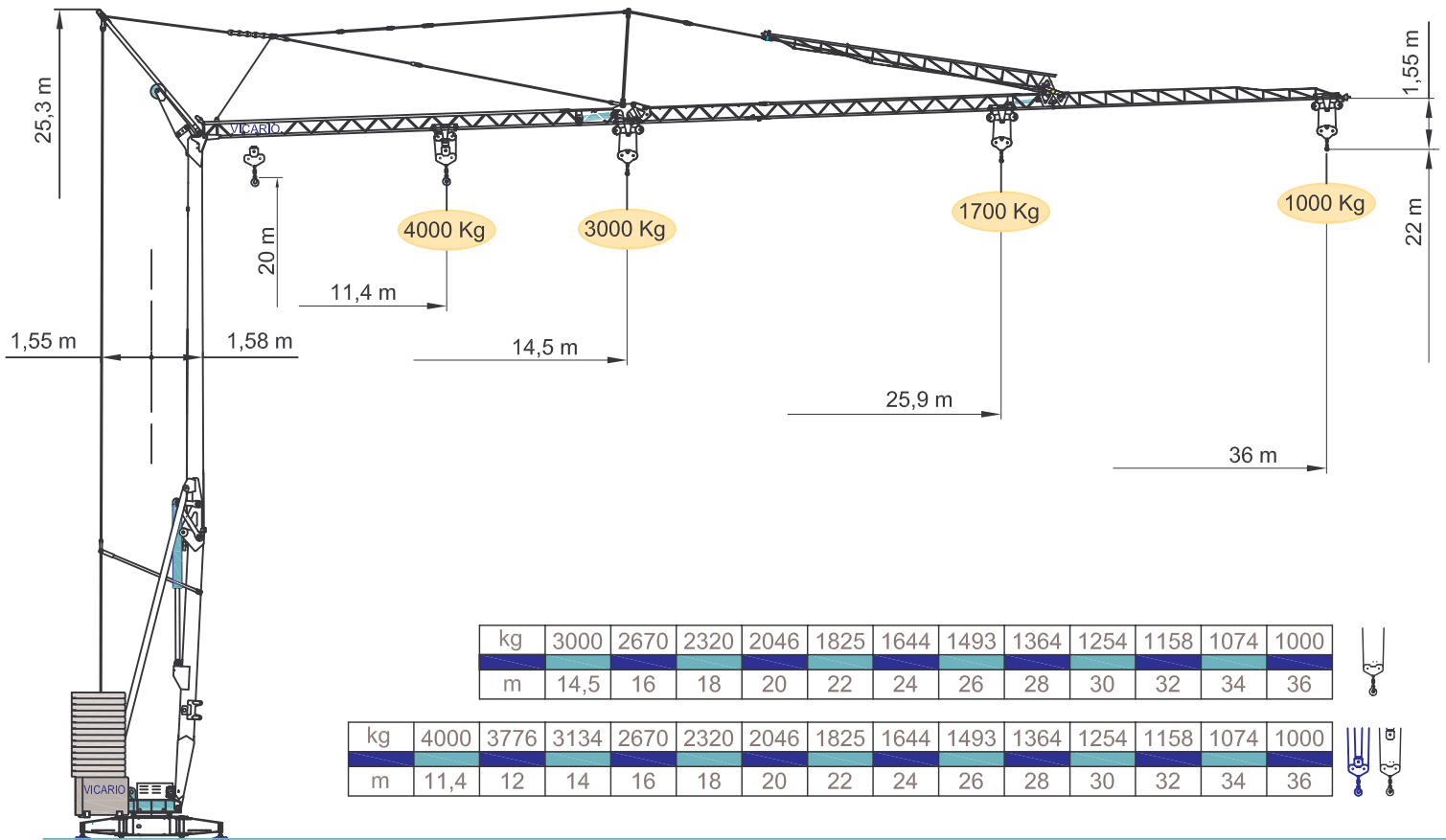

kg	3000	2670	2320	2046	1825	1644	1493	1364	1254	1158	1074	1000
m	14,5	16	18	20	22	24	26	28	30	32	34	36

kg	4000	3776	3134	2670	2320	2046	1825	1644	1493	1364	1254	1158	1074	1000
m	11,4	12	14	16	18	20	22	24	26	28	30	32	34	36

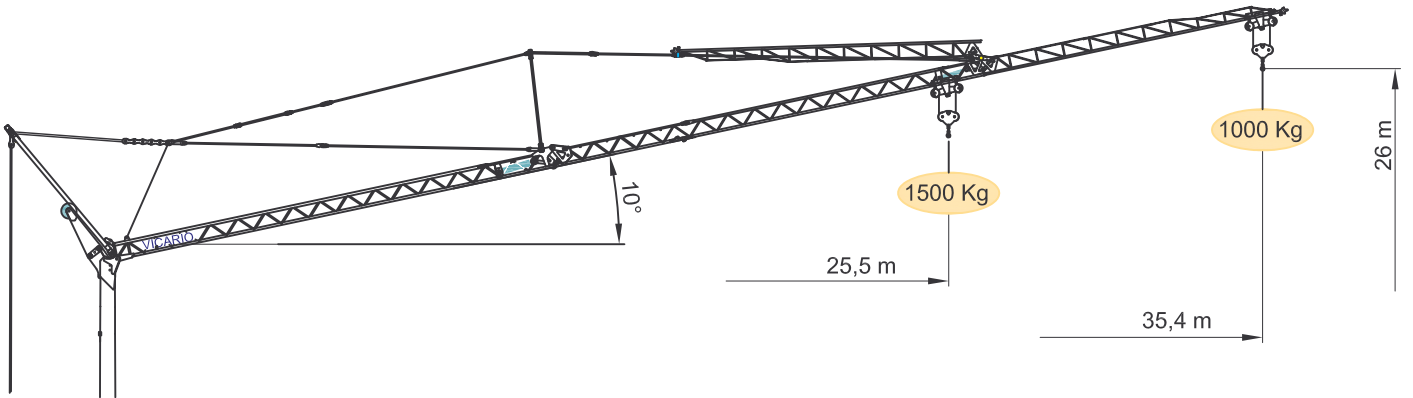
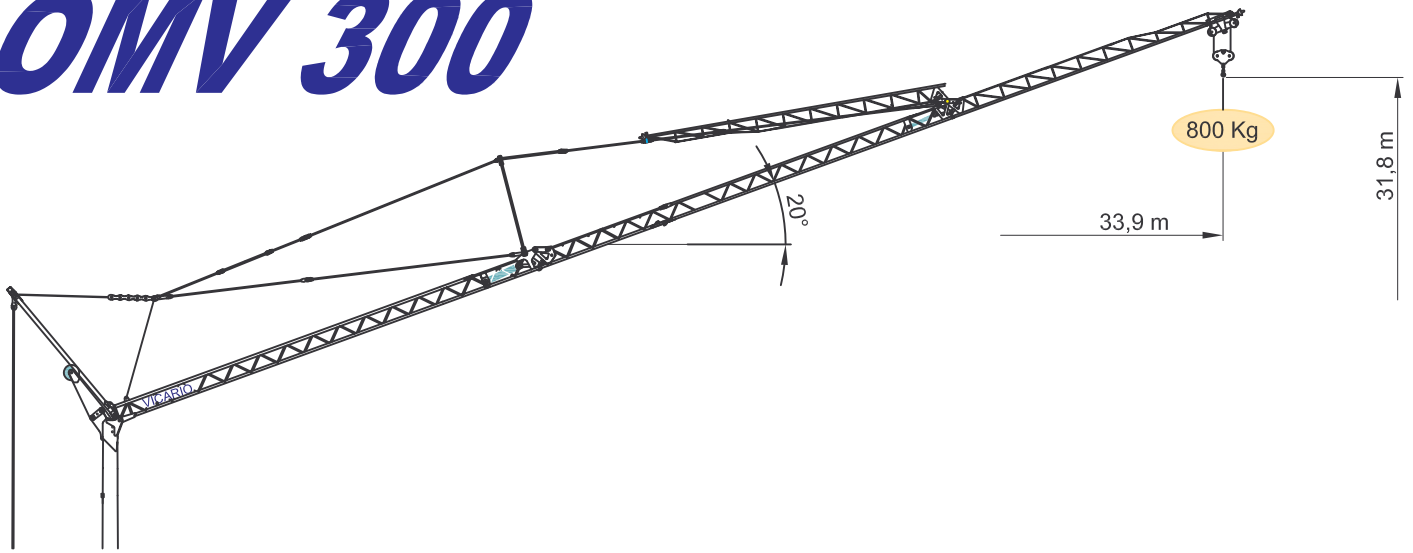



DOTAZIONE DI SERIE

Sollevamento "overdrive" a quattro velocità con inverter, rotazione e carrello a tre velocità con inverter, zincatura della struttura e dei tiranti, contrappeso, braccio impennabile, carrello rampante con motore e finecorsa alla base della torre, funzionamento con braccio ripiegato, comando a pulsantiera via cavo, carter di protezione per ralla e meccanismi, predisposizione per autozavorramento e radiocomando, armadio elettrico in acciaio inox, documentazione a norme CEE.



STANDARD FEATURES

Lifting, 3-speed rotation and trolley with inverter control, galvanised structure, counterweight, pull-up jib, translation trolley with motor and limit switch at base of gantry, operation with jibbed jib, cable-operated pushbutton remote control, guard for shoving ring and mechanisms, designed to allow installation of self-ballasting device and radio control, stainless steel electrical cabinet, documentation in accordance with EU standards.



EQUIPEMENT DE SERIE

Levage a quatre vitesses, chariot et rotation a trois vitesses a contrôle électronique, galvanisation de la structure et des tirants, contrepoids, flèche relevable, moteur de chariot et fin de course a la base de la tour, fonctionnement bras replié, commande par cable, carter de protection pour la couronne et les mecanismes, predisposition pour autostage et commande radio, armoire électrique en acier inox, documentation conforme aux normes CEE.



SERIENAUSSTATTUNG

Heben mit vier Geschwindigkeiten, Laufkatze und Rotation mit drei Geschwindigkeiten, Strukturverzinkung, Gegengewicht, hochklappbarer Arm, aufsteigender Wagen mit Motor und Anschlag an der Basis des Turms, Funktionieren mit eingeklapptem Arm, Steuerung mit Druckknopftaste via Kabel, Schutzvorrichtungen für Dreherschildungen und Mechanismen, Vorbereitung für Selbstballaststuhme und Funksteuerung, elektrischer Schrank aus rostfreiem Stahl, Dokumentation gemäß EC Vorschriften.



DOTACION DE SERIE

Levantamiento a cuatro velocidades, carro y rotación a tres velocidades con control electrónico, galvanización de la estructura, contrapeso, brazo empuñable, carro rampante con motor y fin de carrera en la base de la torre, funcionamiento con brazo replgado, funcionamiento por pulsadores via cable, carter de protección para corona de giro y mecanismos, predisposición para autocontrapeso y radiocomando, armario eléctrico de acero inox, documentación según normas CEE.

	400 V (+10% - 10%) 50 Hz	12 kVA
--	-----------------------------	--------

	m/l'	8	20	46	56
	kg	3000	3000	1200	800
kW		11 (Inverter)			

	m/l'	8-4	20-10	46-23	56-28
	kg	2000-4000	2000-4000	1200-2400	800-1600
kW		11 (Inverter)			

	m/l'	16	26	48.7 (35.7)
	kW	3 (Inverter)		

	g/l'	0.17	0.43	0.85
	kW	3 (Inverter)		

	min	18
	kW	3

	15500 Kg		8000 Kg + 16900 Kg
--	----------	--	--------------------------

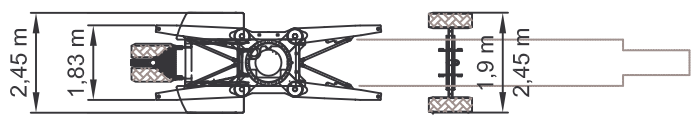
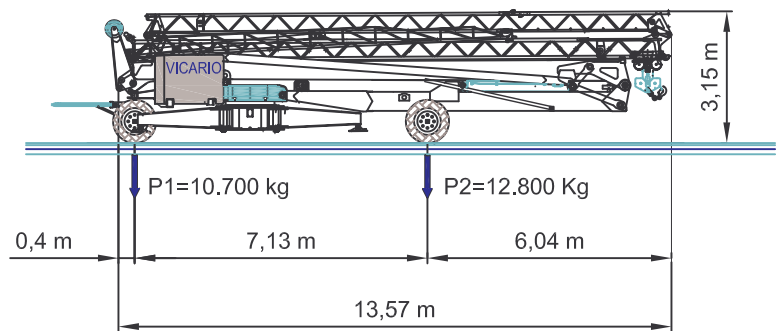
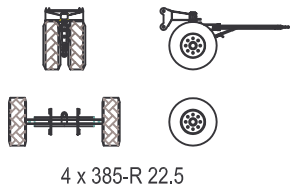

Freni - Brakes - Freins - Bremse - Frenos

